

Hot Melt Extrusion in the Production of Intra-vaginal Rings Containing Antiretroviral Drugs

 ANTEC 2010

May 18th 2010
Andrew Loxley



PARTICLE SCIENCES
DRUG DEVELOPMENT SERVICES



Introduction to Particle Sciences



- CRO servicing the life sciences
- Providing formulation, drug delivery, analytic, and manufacturing services
- Founded in 1991, privately held
- Bethlehem, PA
- 15,000 sq ft
- 40+ employees
- Comprehensive formulations approach
- State-of-the-art chemical and physical characterization methodologies
- cGLP/cGMP, analytic/bioanalytic laboratories
- Class 10,000 and Class 100 clean rooms
- Clinical Trial Material production under cGMP's
 - ✓ Both non-sterile and sterile
- Full ICH stability programs
- Capable of safely handling highly potent compounds



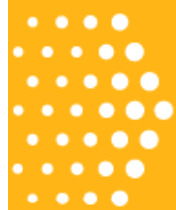

Intra-vaginal Rings

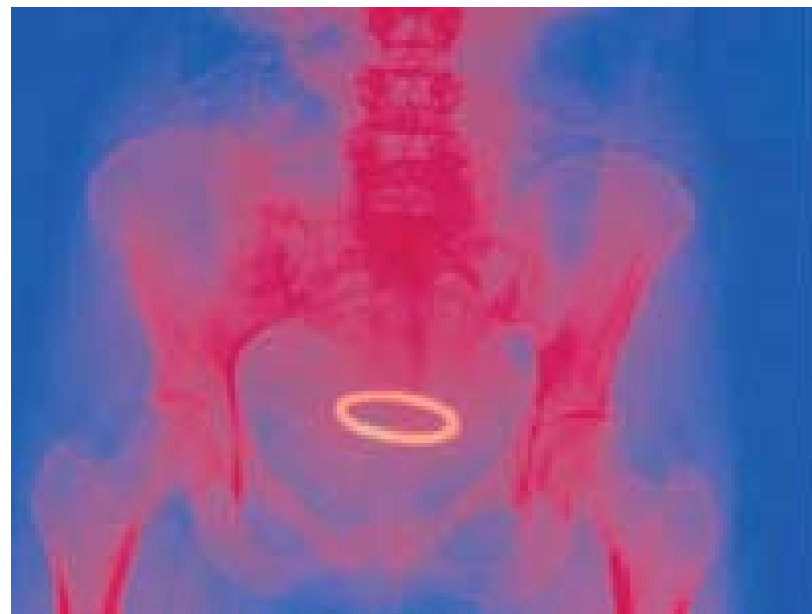

Intra-vaginal Rings - Designs

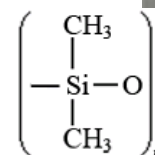
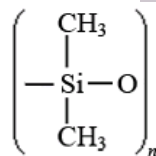
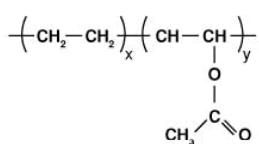
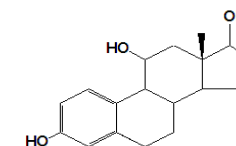
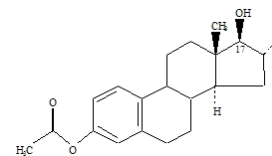
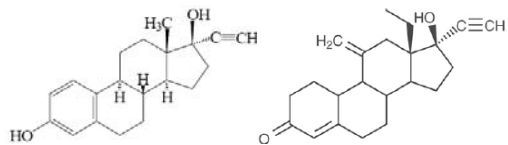

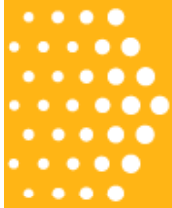

Intra-vaginal Rings - Designs

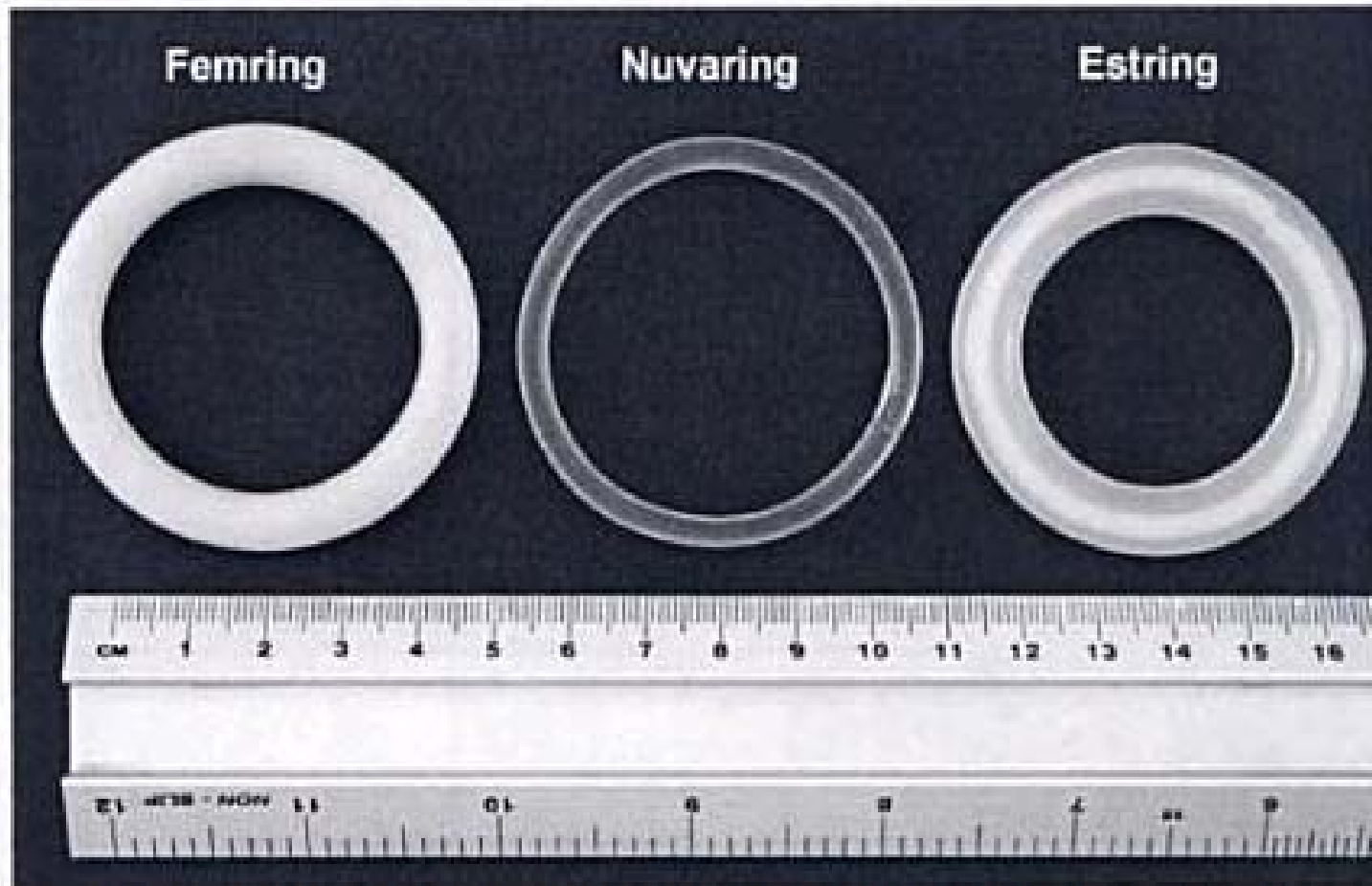

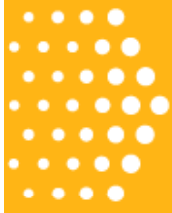

Intra-vaginal Rings – Drug Release Profiles

NUVARING®

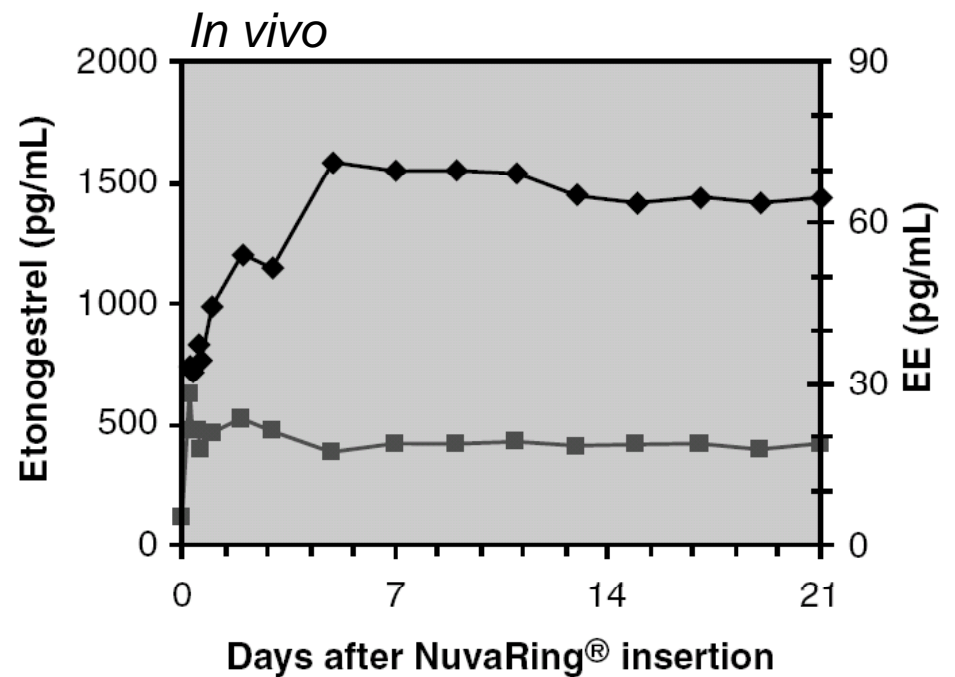
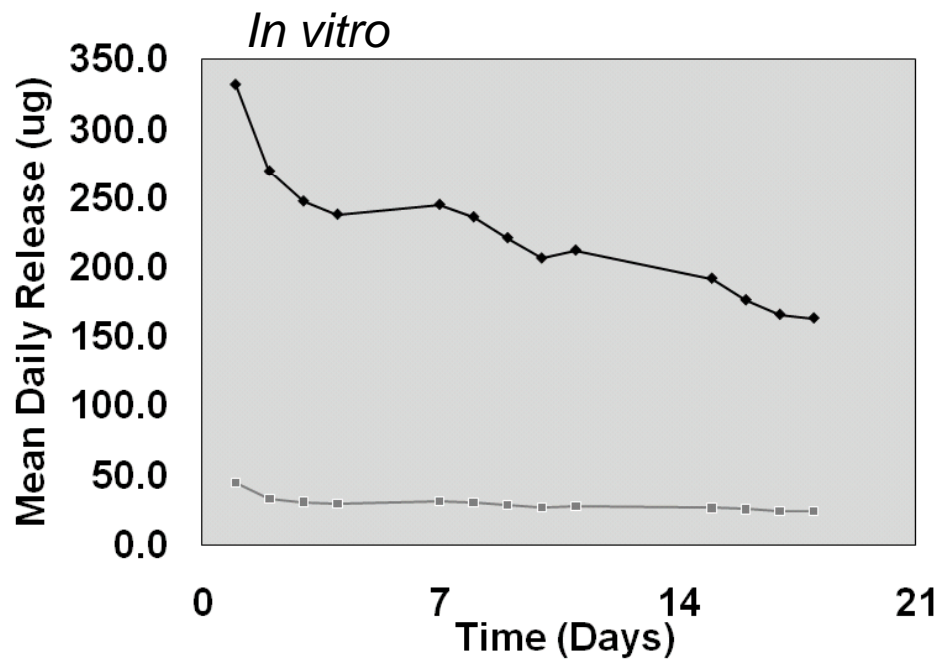

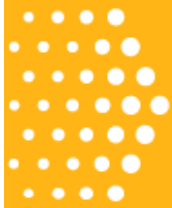

HIV - Global Prevalence in Adults

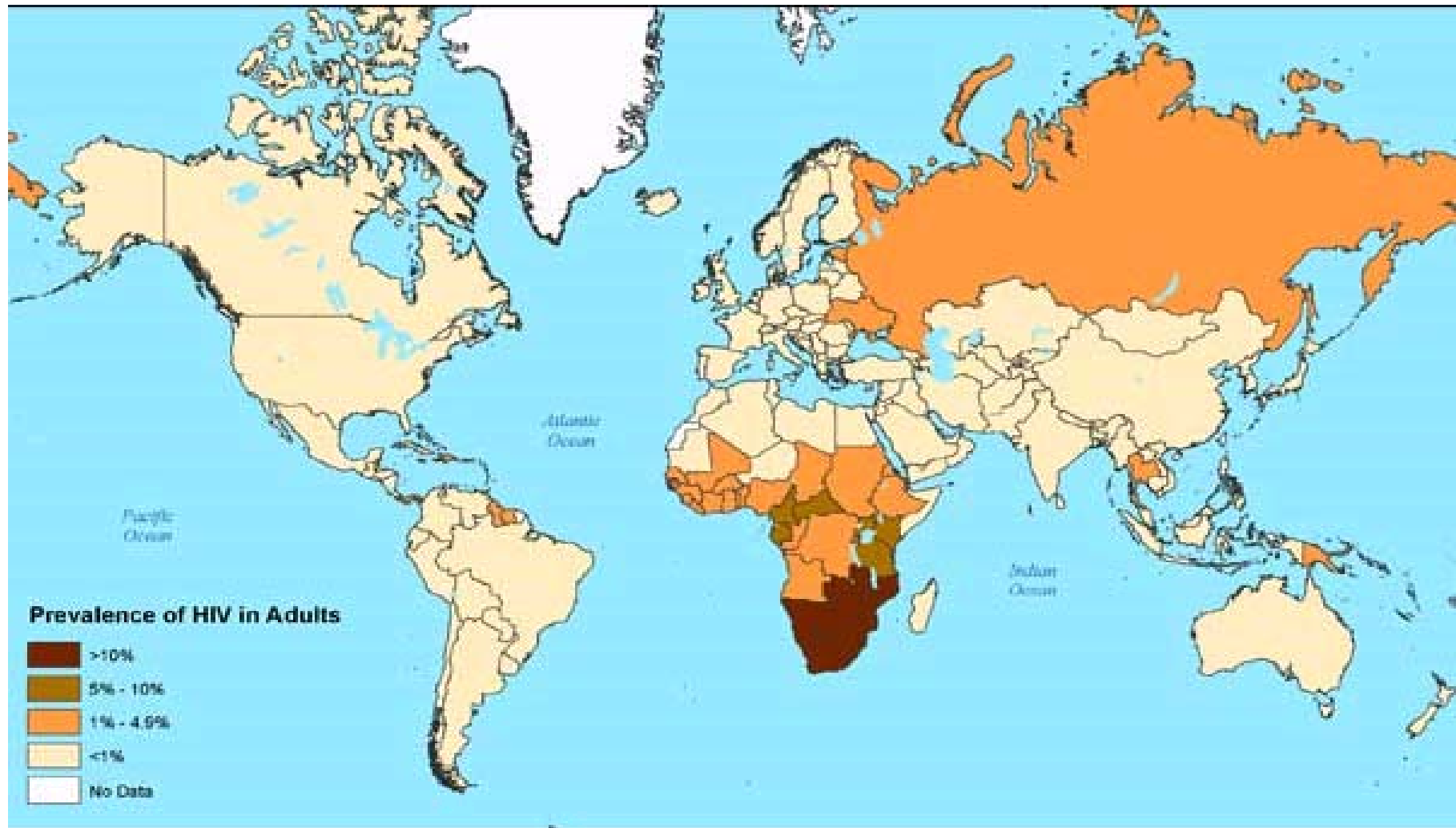



HIV/AIDs and Microbicides

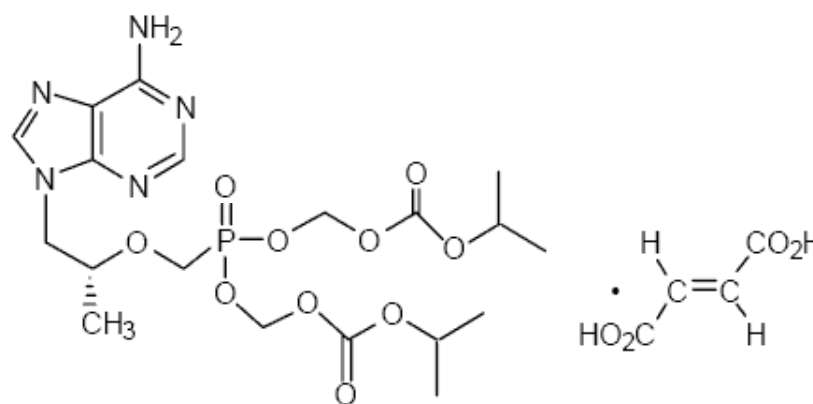
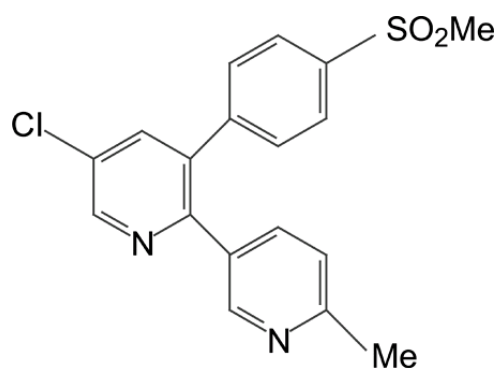
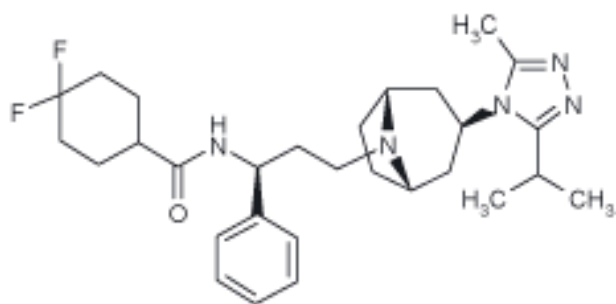
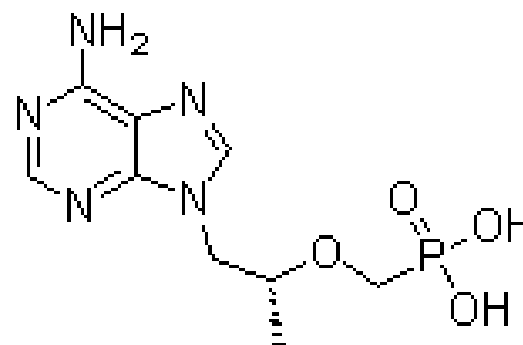
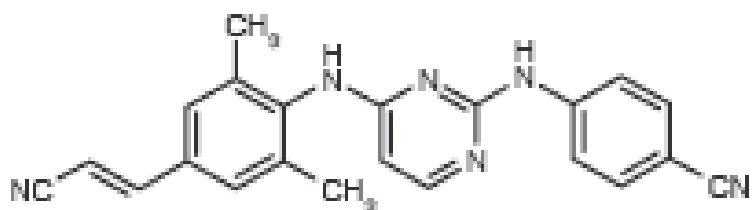

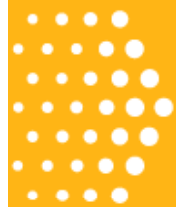

The Driving Force

ARV-loaded IVRs could protect women from infection from HIV+ partners

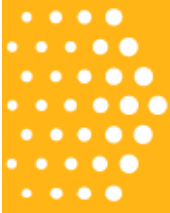

Ethylene Vinyl Acetate (EVA)

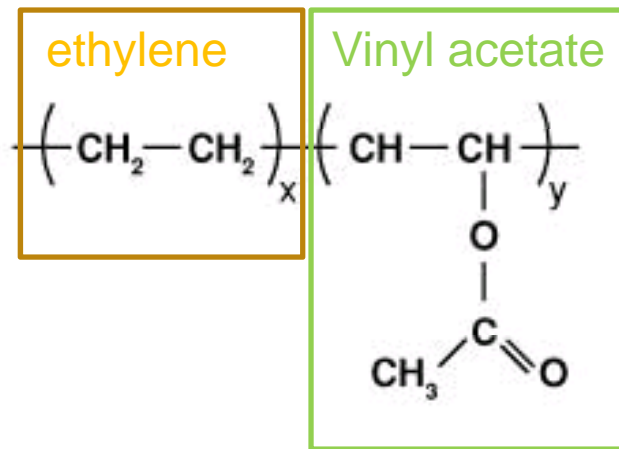

~ 7 – 40 wt%

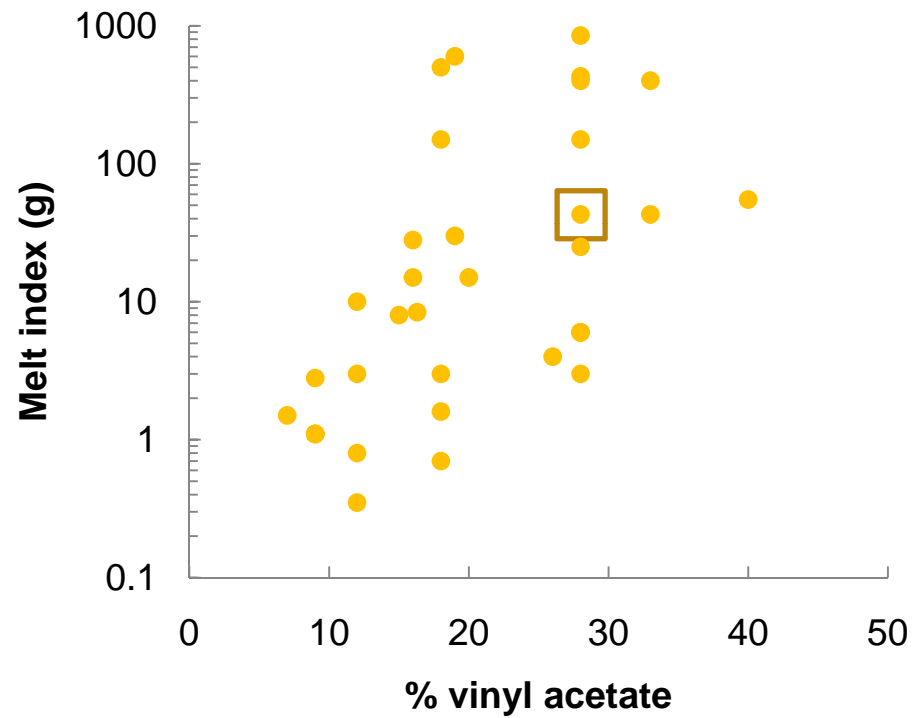

Lab Scale Preparation of Dapivirine / Maraviroc IVRs

Micronize drug powder(s)

Melt EVA in a
Banbury batch mixer

Add API in one shot

Mix
Polymer + drug

Cool

Grind (liquid N₂)

Injection mold crumb to form IVRs



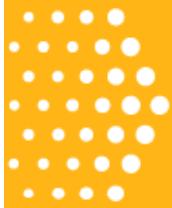

Potential Issues at the Lab-scale

API degradation

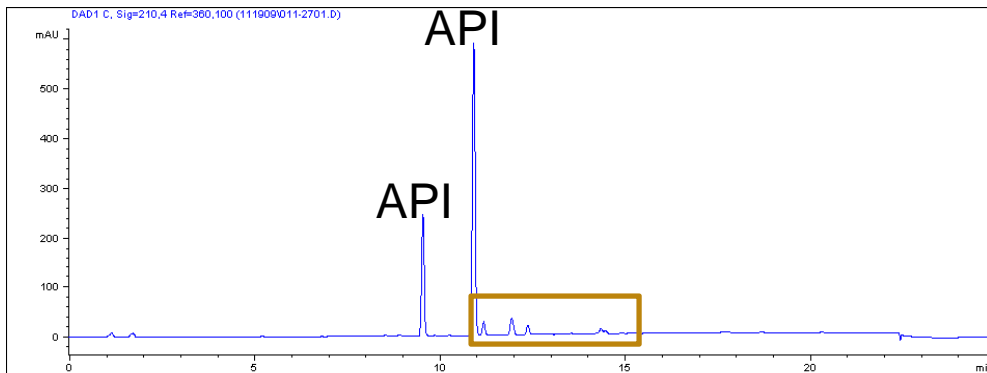

Sample	Process Temp (°C)	Average Degradants (% based on API)
API	-	0.6
API + EVA	155	32.6
API + EVA	141	3.7
API + EVA + 50ppm BHEB	164	1.7
API + EVA + 75ppm BHEB	159	1.9
API + EVA + 100ppm BHEB	161	1.2

Small # of IVRs per batch – not readily scalable

Not sure if performance (especially drug release) will be the same as commercial scale IVRs

Manufacturing Dapivirine / Maraviroc IVRs

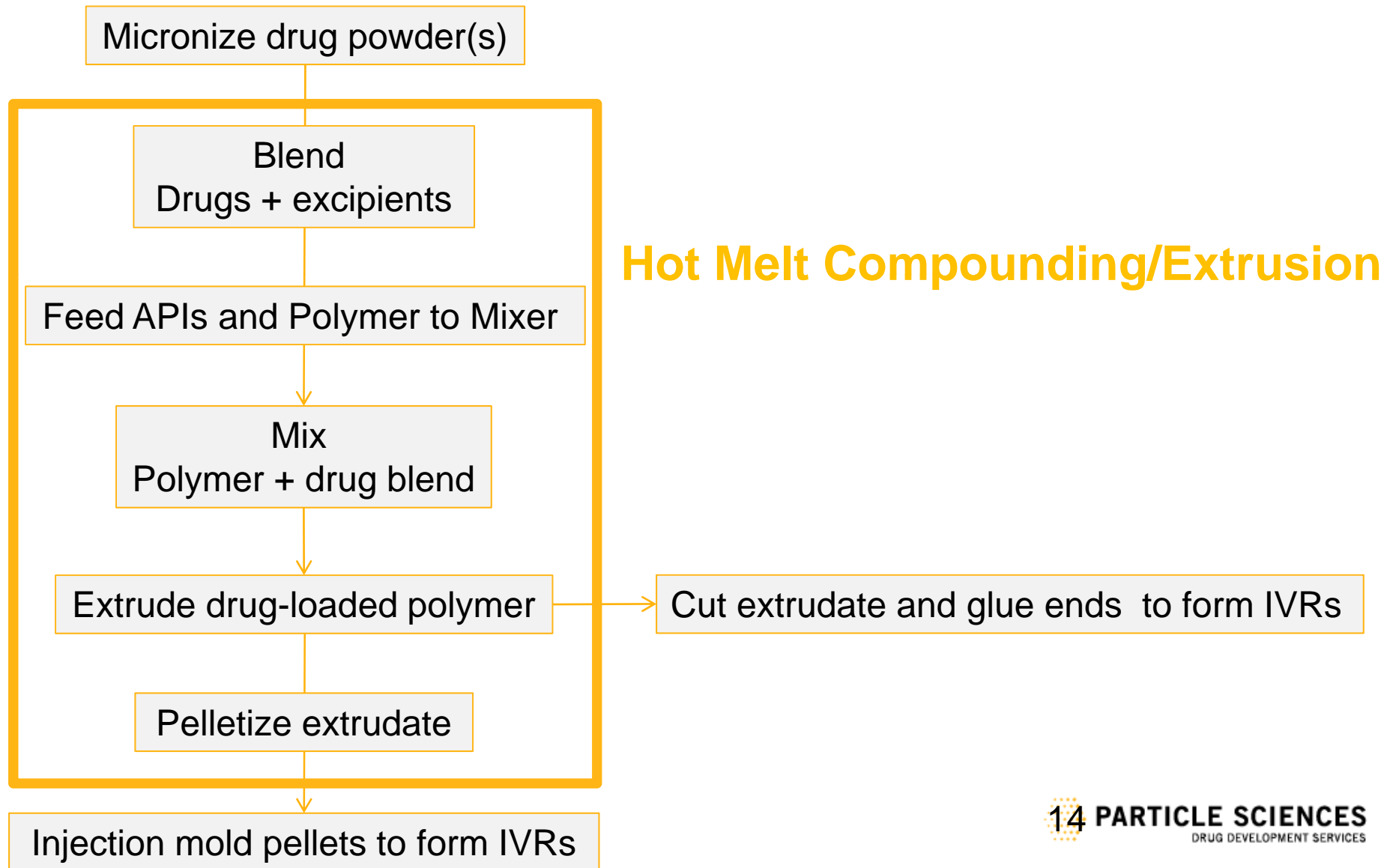

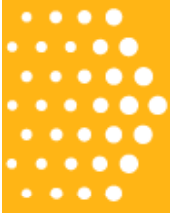

Developing IVR Manufacturing Processes

Blend
Drugs + excipients

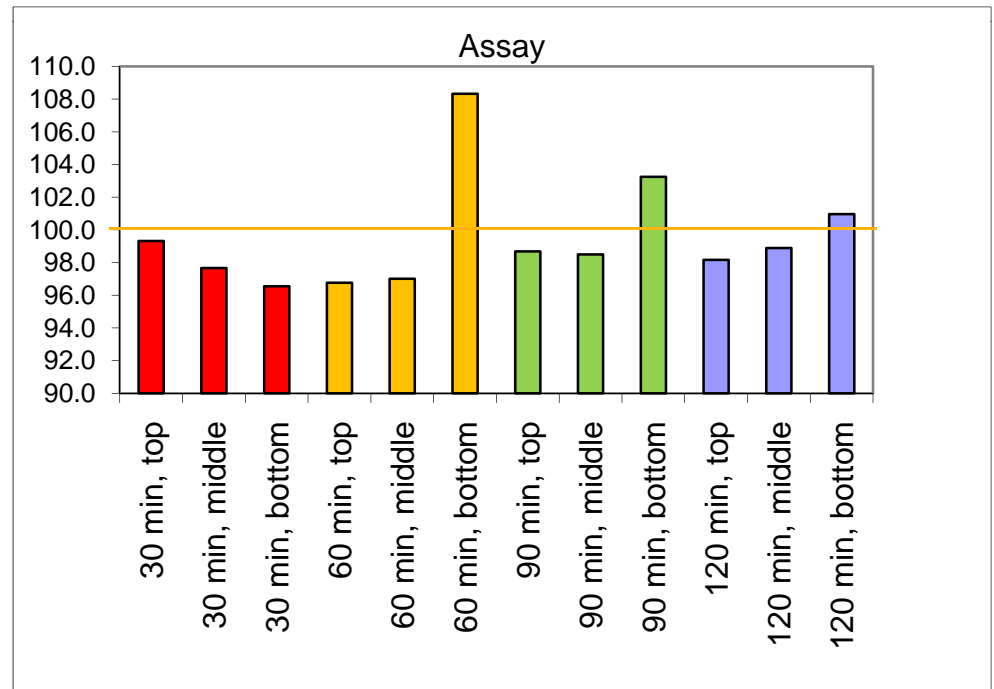
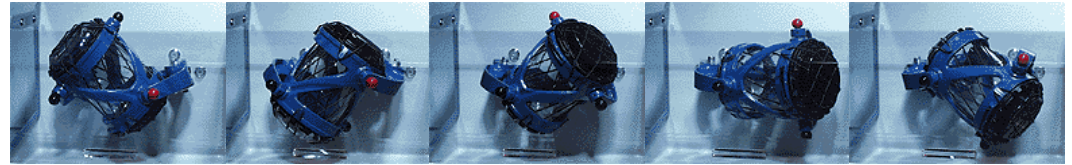

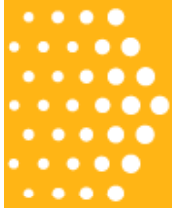

Developing IVR Manufacturing Processes

Blend
Drugs + excipients

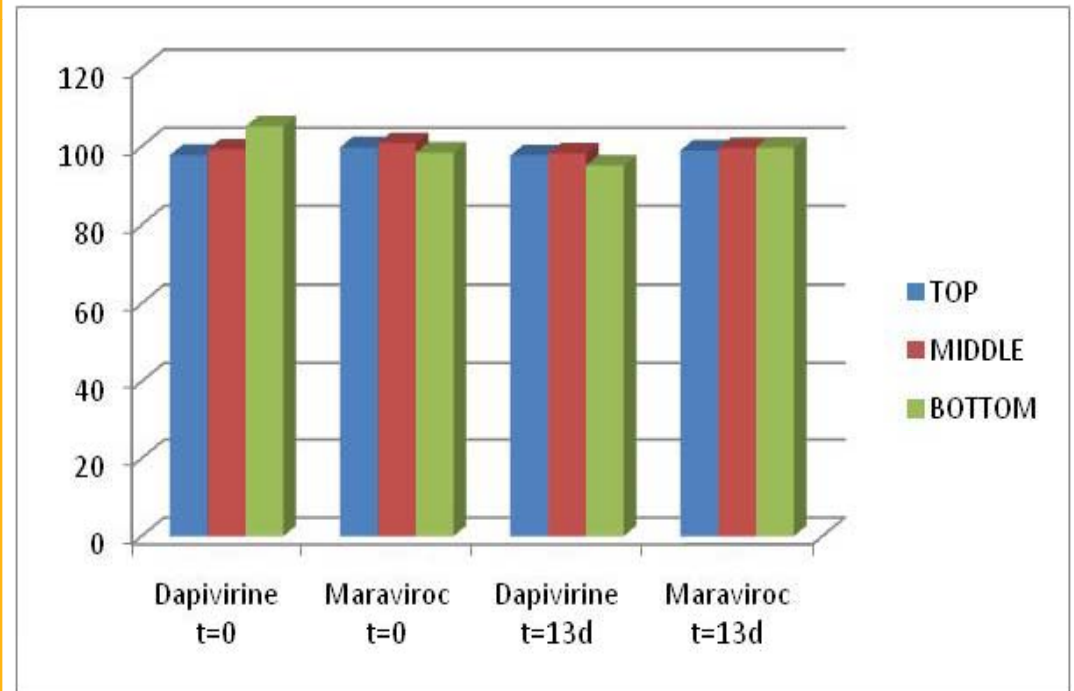
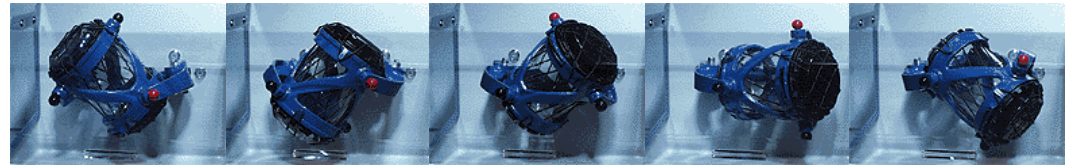

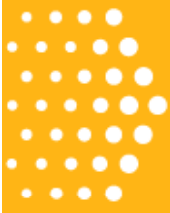

Developing IVR Manufacturing Processes

EVA 3 kg/h, 1.3% Dapivirine, 5.6% Maraviroc

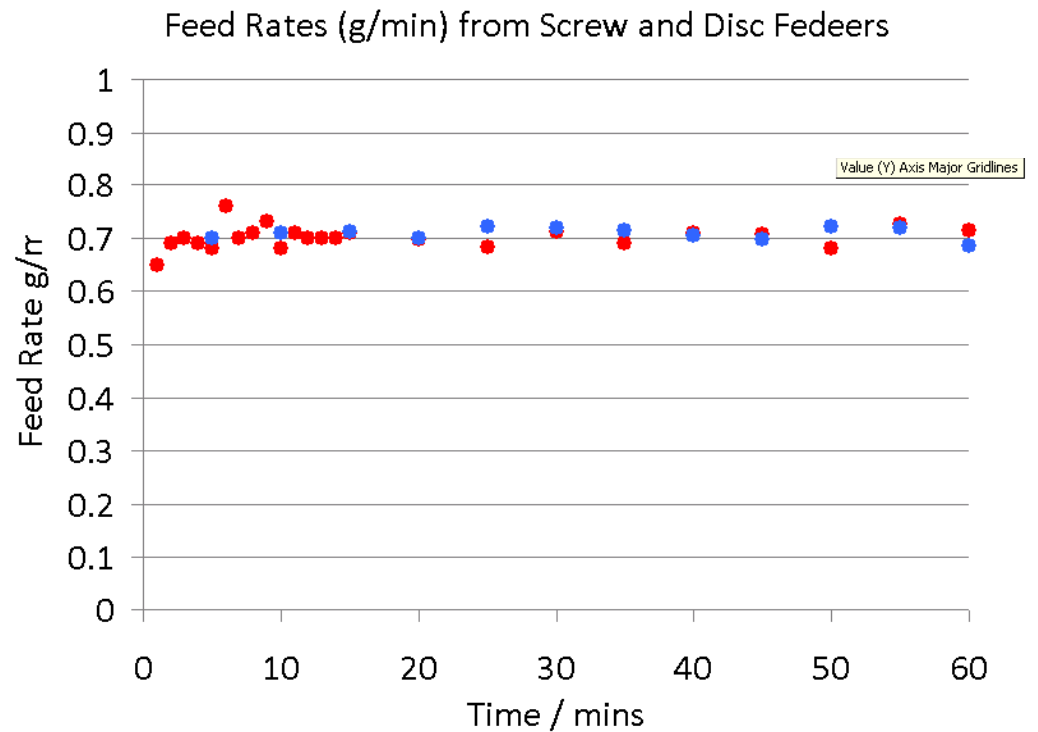
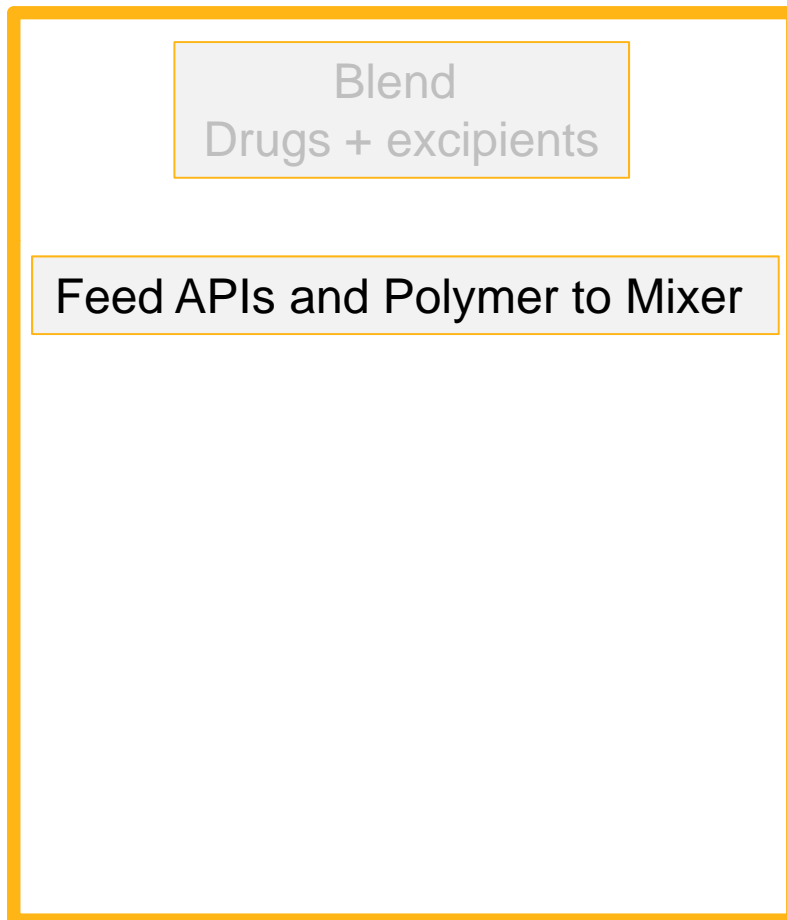

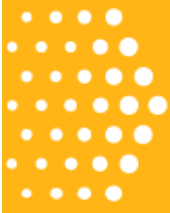

Developing IVR Manufacturing Processes

EVA 3 kg/h, 1.3% Dapivirine, 5.6% Maraviroc

Blend
Drugs + excipients

Feed APIs and Polymer to Mixer

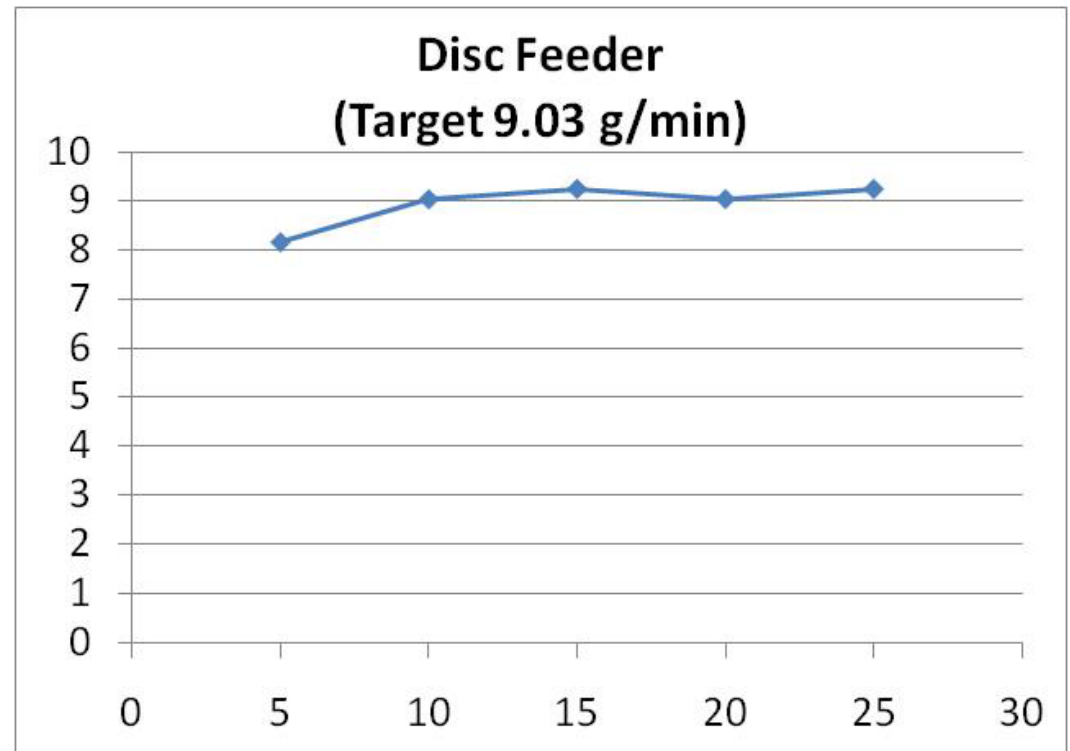

Developing IVR Manufacturing Processes

Blend
Drugs + excipients

Feed APIs and Polymer to Mixer

Mix
Polymer + drug blend

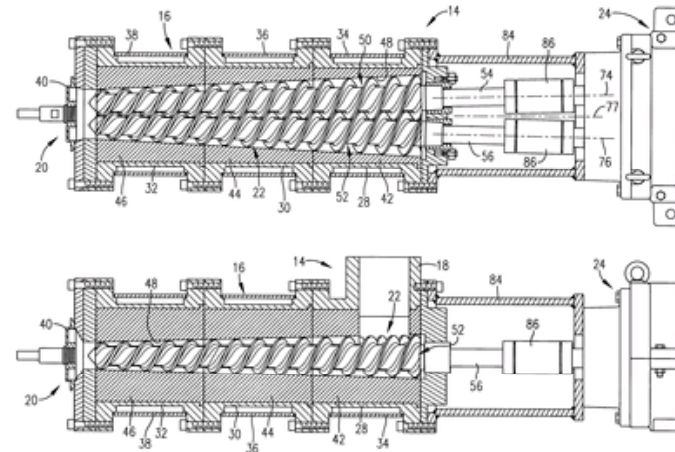

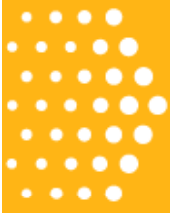

Developing IVR Manufacturing Processes

Powder / Polymer Mixing

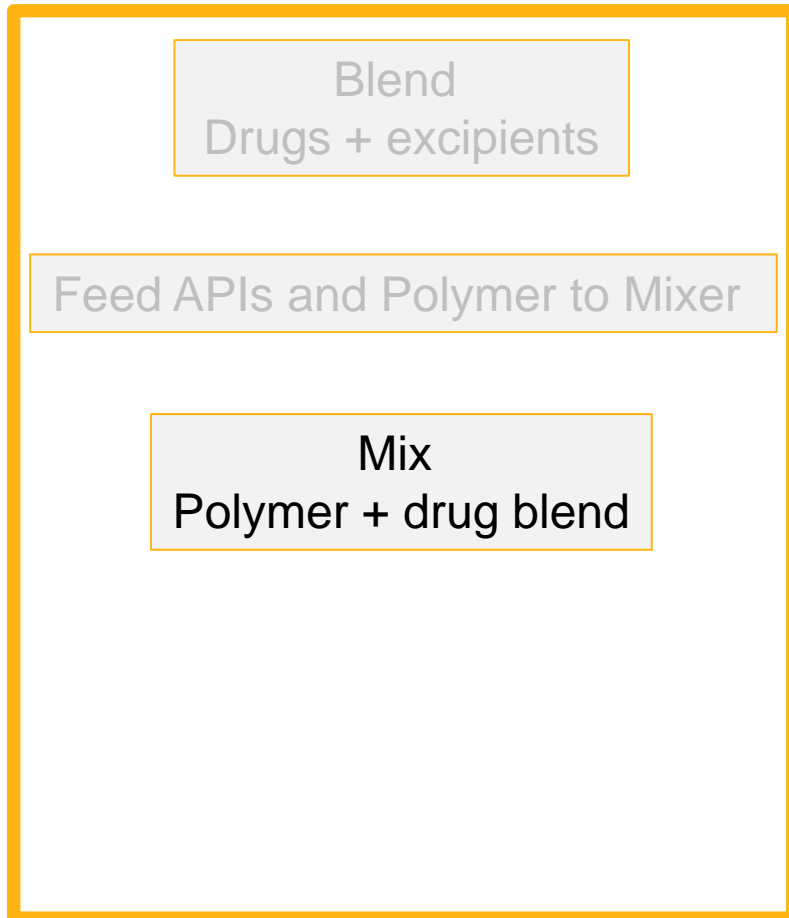

Considerations:

- * thermal stability of API
- * thermal stability of polymer
- * residence time
- * mixing efficiency and homogeneity / API solubility in polymer (DSC?)

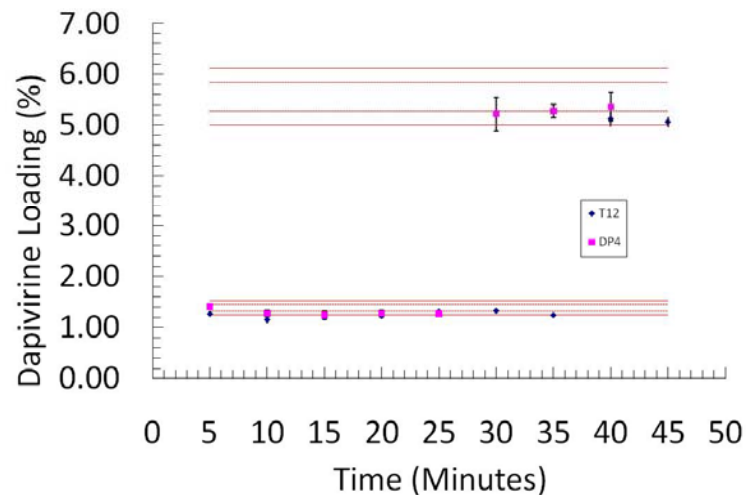

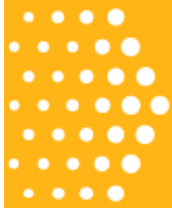

Developing IVR Manufacturing Processes

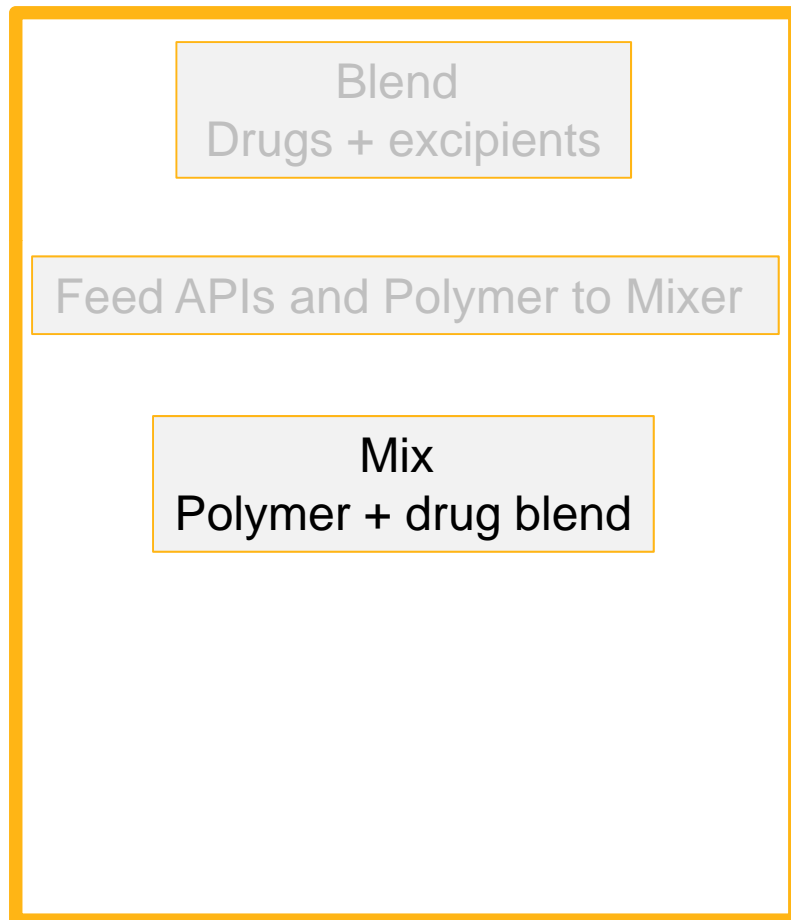

Benefits of HME over Batch Processes

Lower Processing Temperature and shorter residence time

Reduced API degradation

Reduced Polymer degradation

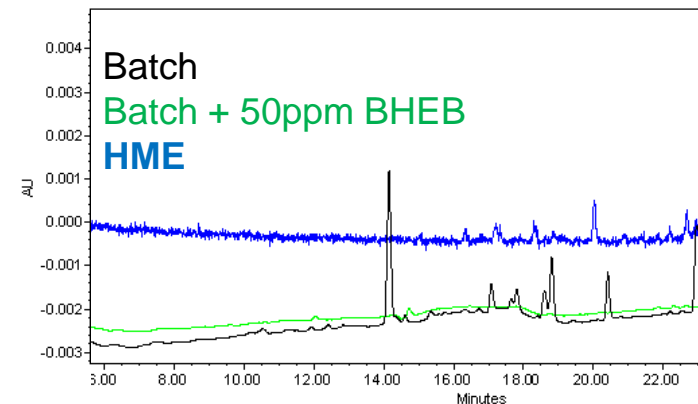

Continuous process

Easy conversion to pellets

Higher throughput

Product uniformity

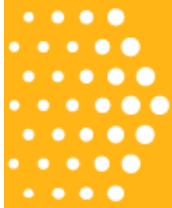

Developing IVR Manufacturing Processes

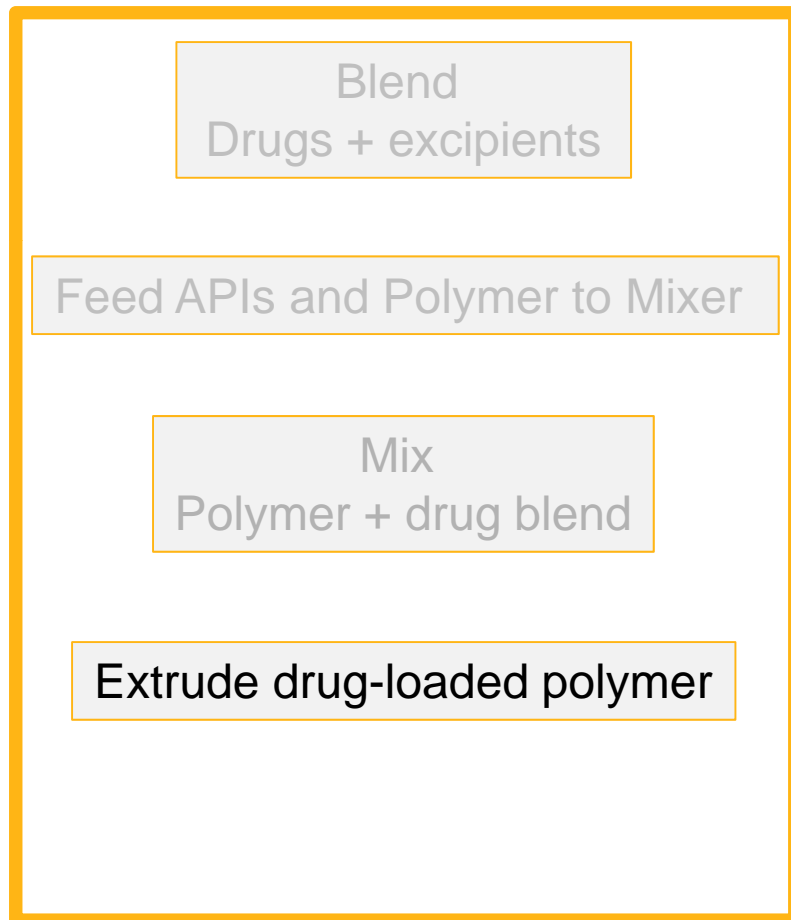

Die options

single orifice
double orifice
diameter

Choice of conveyor belt

Choice of cooling (water, air...)

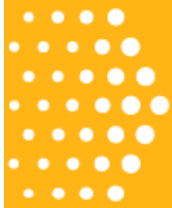

Developing IVR Manufacturing Processes

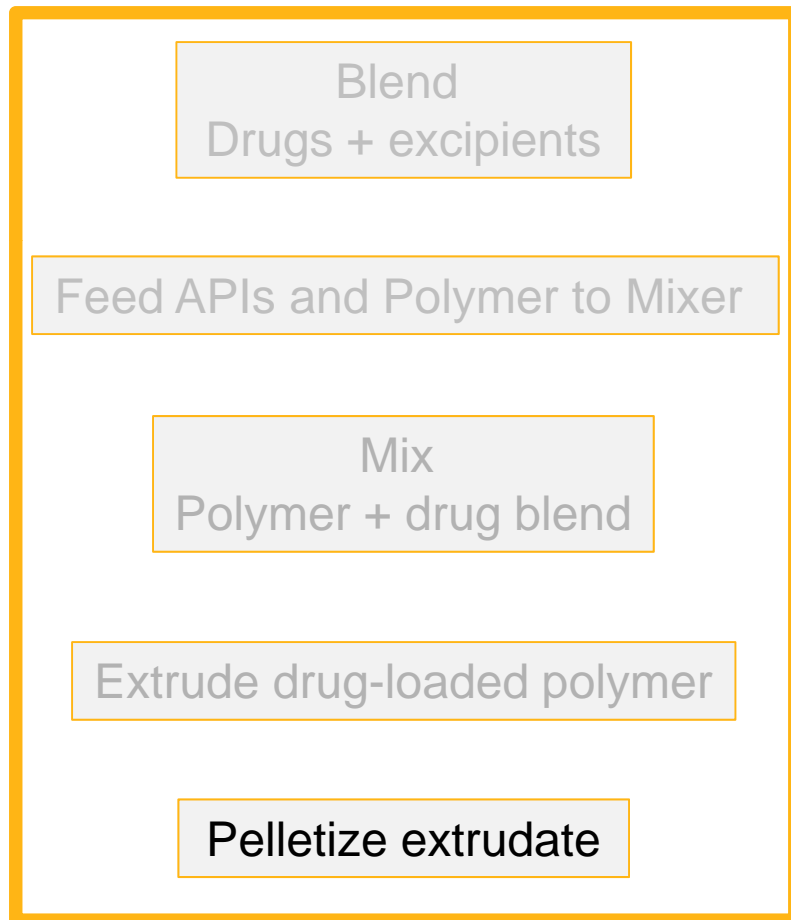

Pellets required to feed Injection Molder

Choice of pelletizer

Effect of speed etc on pellet size and uniformity

Collection of pellets

Assay pellets

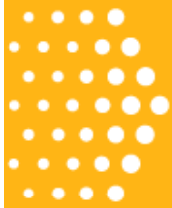

Developing IVR Manufacturing Processes



Process Development
time
temperature
injection rate
cooling

Mold design
gate
sprue removal
push pins

Injection mold pellets to form IVRs

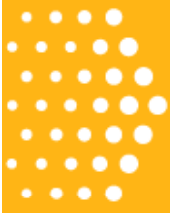

In-vitro Drug Release Results

Compare Banbury batch IVRs with ZSE18Nissei IVRs for release of Dapi and DS006

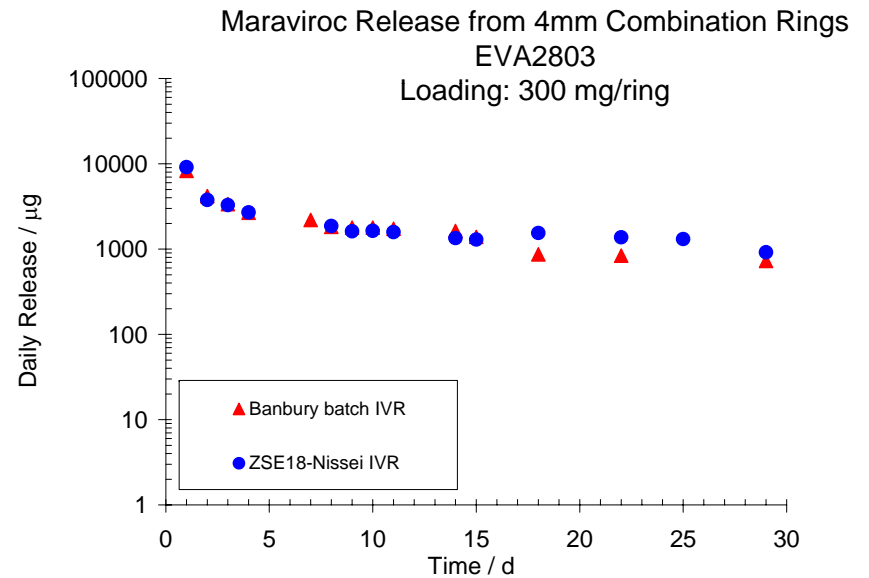
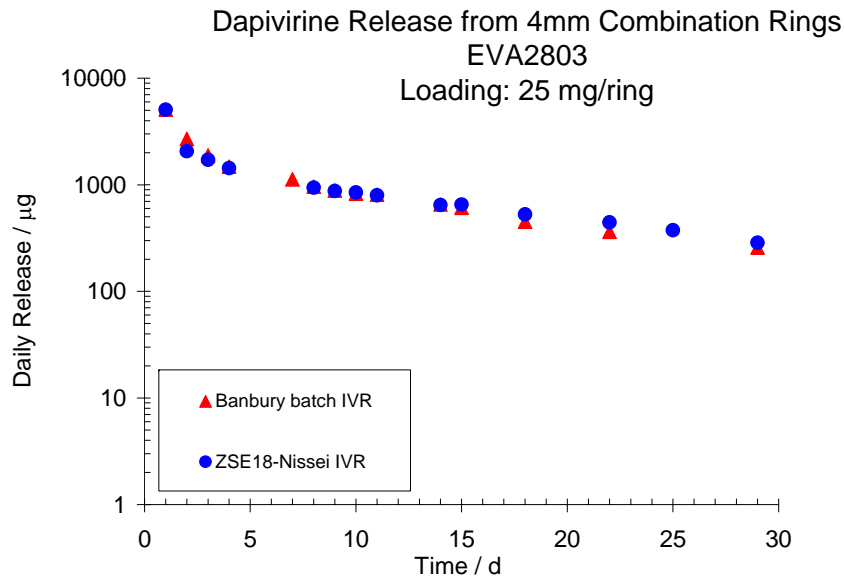

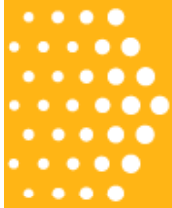

Regulatory Considerations

For human clinical trials

cGMP

raw materials purchasing, qualification, storage,
handling

personnel qualifications

qualified equipment (IQ, OQ, PQ)

validated analytical methods

validated production processes

MOC not additive, reactive nor absorptive

validated cleaning procedures required

QBD development approach (design space)

QA oversight of production

Batch record

Stability study following ICH guidelines

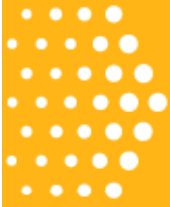

Conclusions

Batch-wise compounding is suitable for small scale formulation development

There are issues associated with small scale processing that may not be observed at production scale

Hot Melt Extrusion

- requires upstream process development (powder blending, powder feeding)

- May reduce degradation of key materials

- Yields uniform, high quality compound

- Is readily scaled to commercial volumes

- Is the process of choice for EVA matrix IVRs

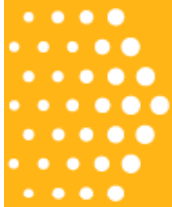

Acknowledgements



PSI

Jason McConnell

Onajite Okoh

Jigar Patel

Matthew Bigert

Christopher Morgan

Leistritz

K-Tron

Scheck-Accurate